

# CBQ30

## Assembly Instructions

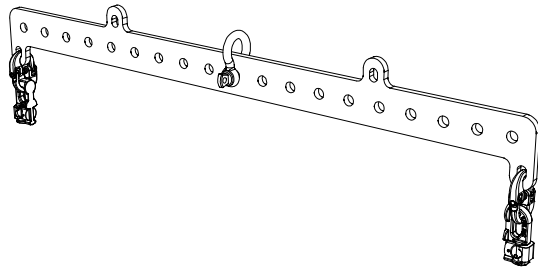

## Introduction

Thank you for choosing a high-quality product “MADE IN GERMANY” from the brand TWAUDIÖ.

The cradle bar for flying CBQ30 is an accessory for the VERAS30 loudspeaker.

It is characterized by a subtle look, a remarkable size to weight ratio and ease of use.

If you lend your product to another party, inform that party of the safety-related operating procedures and hand over this assembly guide. If you require additional copies of this manual, you can obtain them free of charge from TWAUDIÖ or download them from [www.twaudio.de](http://www.twaudio.de)

### Instructions in this user manual

Strictly adhere to the instructions contained in this operating manual that are marked as follows:



This symbol in combination with the signal word “Warning” identifies a potentially hazardous situation. Failure to comply with this safety instruction can lead to serious injury or even death.



This symbol in combination with the signal word “Caution” identifies a potentially hazardous situation. Failure to comply with this safety instruction can lead to light or moderate injury.



This symbol in combination with the signal word “Note” identifies a potentially hazardous situation. Failure to comply with this safety instruction can lead to product damage.



This symbol in combination with the signal word “Tip” identifies additional information or notes that will simplify working with TWAUDIÖ products on the basis of practical experience.

## Notes on the products

**Read manual  
before use!**

Before using the device, carefully read the assembly instructions and keep it with the CBQ30 cradle bar for flying.

## General information

Assembly instructions: OM-CBQ30  
Version 2.0 en, 07/2022  
© by TWAMBO 2023; all rights reserved.

All information contained in this operating manual was correct to the best of our knowledge at the time of printing.

Quality warranties or assurance of suitability for a certain type of use based on the technical specifications, dimensions and weights are not granted by TWAMBO.

TWAMBO also shall not assume liability for any secondary damage (property damage and/or personal injury) nor for the failure to comply with this operating manual!

TWAMBO reserves the right to update this document based on recent developments.

TWAMBO GmbH  
Karl-Hofer-Str. 42  
14163 Berlin  
Germany

Phone : + 49 (0) 71 41-48 89 89 0  
Fax: + 49 (0) 71 41-48 89 89 99  
E-Mail: [info@twaudio.de](mailto:info@twaudio.de)  
WWW: [www.twaudio.de](http://www.twaudio.de)

## Content

1. Safety   Intended use.....	5
2. Overview .....	7
2.1 Components .....	7
3. Technical data .....	8
3.1 Data sheet.....	8
4. Commissioning.....	9
4.1 Setup .....	9
4.2 Wind load .....	9
4.3 System setup CBQ30 to VERAS30 loudspeaker .....	10
4.4 System setup CBQ30 to VERAS30 loudspeaker - cardioid mode .....	12
5. Transport and storage .....	14
6. CE Conformity Declaration.....	15
7. Disposal .....	15

## 1. Safety | Intended use

Please adhere to the following safety instructions to avoid risks when using accessories.

The CBQ30 cradle bar for flying was developed for use in professional sound systems. The cradle bar for flying may only be used by trained and qualified personnel.

Note the operating modes described in this assembly instructions. Other uses are not permissible.

Damage caused by improper use is not covered by TWAMBO.



Before every operation, check the scope of delivery of the CBQ30 cradle bar for flying for its completeness and ensure that all parts are in perfect condition.



The CBQ30 cradle bar for flying may only used with the VERA S30 loudspeaker.

This rigging manual describes how to use the CBQ30 cradle bar for flying correctly. Any other use shall be deemed improper and may result in damage or even injury.

Modifications or alterations to individual parts of the CBQ30 cradle bar for flying are not permitted! Danger to life!



The CBQ30 cradle bar for flying is designed both for indoor and outdoor use.



The CBQ30 cradle bar for flying may only be used by trained and qualified personnel. Personnel must check the CBQ30 cradle bar for flying for suitability before each use.



The CBQ30 cradle bar for flying must be taken out of operation immediately as soon as visible damage to the parts can be seen.



Please keep all elements of the CBQ30 cradle bar for flying away from children! The small parts can easily be swallowed and lead to suffocation!



## NOTE

When working with heavy loads exceeding 20 kg (44 lbs.), use suitable aids (dollies, hoisting slings, etc.). Multiple persons may be required depending on the situation.



## WARNING

The payload of the CBQ30 cradle bar for flying is designed for not more than six VERAS30 loudspeaker. Do not exceed this payload.



## WARNING

Check the Double Stud connections each time you install the CBQ30 cradle bar for flying. They must be firmly engaged and secured with a safety locking splint. If this is no longer possible, the Double Stud connections with the safety locking splints must be replaced.



## WARNING

Before mounting the CBQ30 cradle bar for flying check that e.g. ceilings are capable of carrying the payload of the components.



## WARNING

Make sure that no water pipes, electrical lines or any other lines are behind the intended place of mounting.



## WARNING

Only use wall plugs and screws which are suitable for the intended mounting and structural fabric. All screws must be set and tightened properly. Ensure that the fixing holes have the correct depth and diameter. Always use all fixing holes.



## WARNING

When moving (assembling, dismantling, maintaining) the CBQ30 cradle bar for flying with VERAS30 loudspeaker, ensure sufficient space to prevent collisions with other objects.



## CAUTION

Do not squeeze or twist the electrical cables of the VERAS30 loudspeaker during the installation of the CBQ30 cradle bar for flying! The respective national electrotechnical rules and regulations are applicable.

## 2. Overview

### 2.1 Components

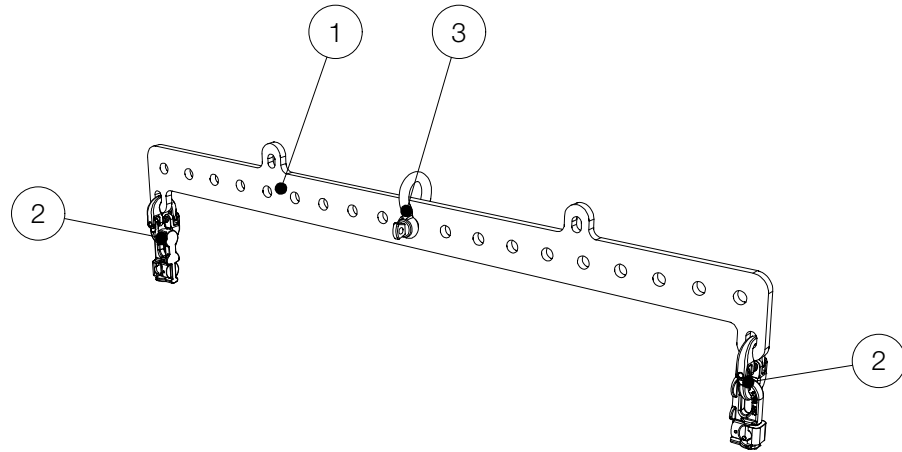

**Figure 2.1 - Overview**

- |    |   |          |
|----|---|----------|
| 1. | Cradle bar for flying .....                   | 1 piece  |
| 2. | SAF-connector with Double Stud + splint ..... | 2 pieces |
| 3. | Shackle SK10.....                             | 1 piece  |

### 3. Technical data

#### 3.1 Data sheet

Maximum load capacity	6x VERAS30
Maximum load capacity at cardioid mode	3x VERAS30
Dimensions (h x w x d)	753 x 106 x 8 mm [29.65 x 4.17 x 0.31 in]
Weight	2,7 kg [5.95 lbs]
Surface	Powder-coated



## 4. Commissioning

### 4.1 Setup

The CBQ30 cradle bar for flying is designed for hanging operation. TWAUDIÖ provides a wide range of accessories to securely attach the swivel bracket.



Please note that setting up the CBQ30 cradle bar for flying always requires two persons!



TWAUDIÖ recommends using only the accessories specified by TWAUDIÖ for securing and mounting loudspeakers.

### 4.2 Wind load



Before setting up the system outdoors, consider unexpected wind conditions at the operation site!

Disassemble your system immediately when wind speeds exceed 8 bft (34 to 40 kn / 62 to 74 kph / 38.5 to 46 mph) and secure the system components!

Make sure that there are no persons in the immediate vicinity of the system structure!



Make sure that the system structures are not operated over the audience at wind speeds in excess of 6 bft (22 to 27 kn / 39 to 49 kph / 24.2 to 30.45 mph) and that there are no persons in the immediate vicinity of the system structure!

### 4.3 System setup CBQ30 to VERA S30 loudspeaker

General safety instructions for setting up this rigging variant:



Use a shackle that is designed according to the payload for each system setup.



Fasten the CBQ30 cradle bar for flying with a shackle and chain hoist according to the middle pin point.



For the secondary safety component, the respective national electrotechnical regulations apply.



Attach this secondary safety component by using two furthermore shackles, chain sling or chain hoist on two another pin points.



Any influences on your system setup, such as leaning against objects (or people) and flying objects around, be refrained from!



Mount a maximum of six VERAS30 loudspeakers one below the other as shown in figure 4.3. Be sure to use BLT24 Boxlink connecting cables on both sides to connect the VERAS30 loudspeakers to each other.



Snap all Double Studs firmly into the flight panels of the VERAS30 loudspeakers! Secure all Double Studs with the safety locking splints attached to safety wire ropes!



Check that all Double Studs are engaged and that they have been secured with safety locking splints!

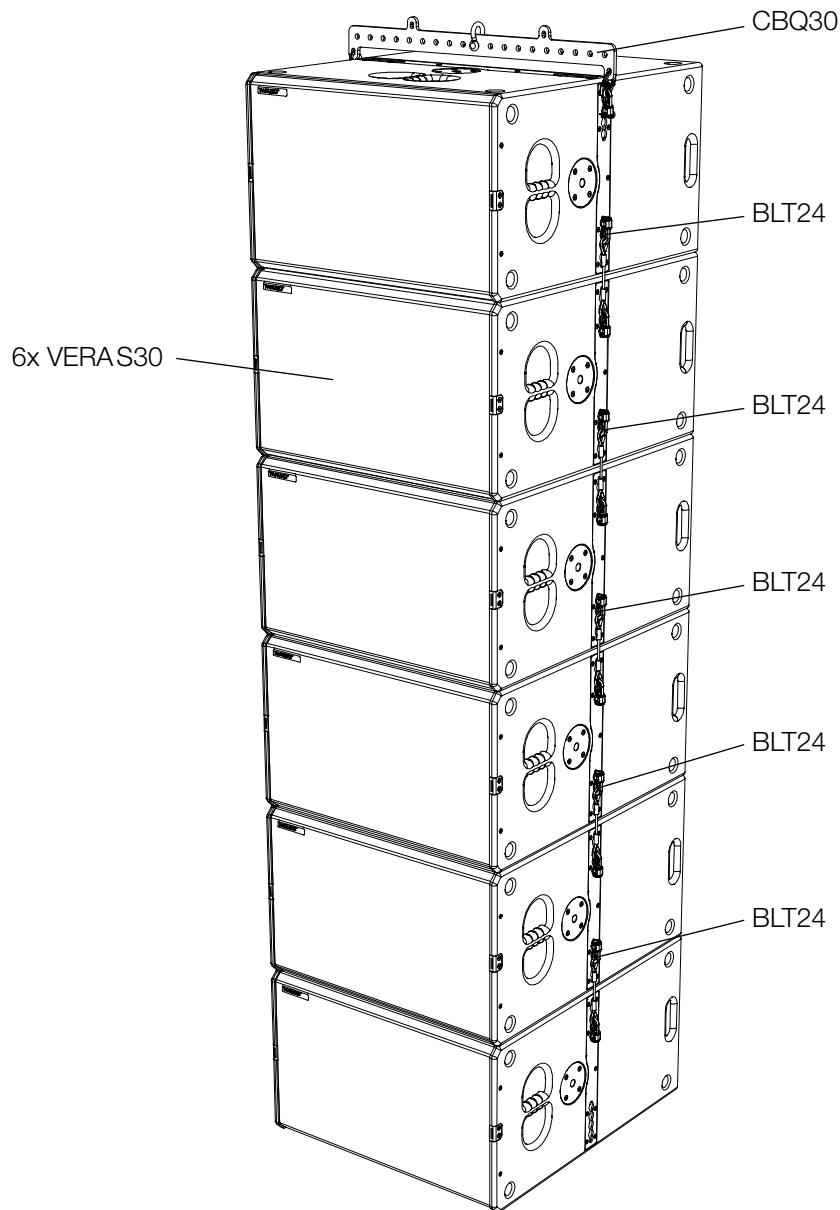

Figure 4.3 - System setup CBQ30 with VERAS30 loudspeaker

4.4 System setup CBQ30 to VERA S30 loudspeaker - cardioid mode

General safety instructions for setting up this rigging variant:



In cardioid mode, mount a maximum of three VERA S30 loudspeakers one below the other!



Use a shackle that is designed according to the payload for each system setup.



Fasten the CBQ30 cradle bar for flying with a shackle and chain hoist according to the middle pin point.



For the secondary safety component, the respective national electrotechnical regulations apply.



Attach this secondary safety component by using two furthermore shackles, chain sling or chain hoist on two another pin points.



Any influences on your system setup, such as leaning against objects (or people) and flying objects around, be refrained from!



Mount a maximum of three VERAS30 loudspeakers one below the other as shown in figure 4.4. Be sure to use BLT24 Boxlink connecting cables on both sides to connect the VERAS30 loudspeakers to each other.



Snap all Double Studs firmly into the flight panels of the VERAS30 loudspeakers! Secure all Double Studs with the safety locking splints attached to safety wire ropes!



Check that all Double Studs are engaged and that they have been secured with safety locking splints!

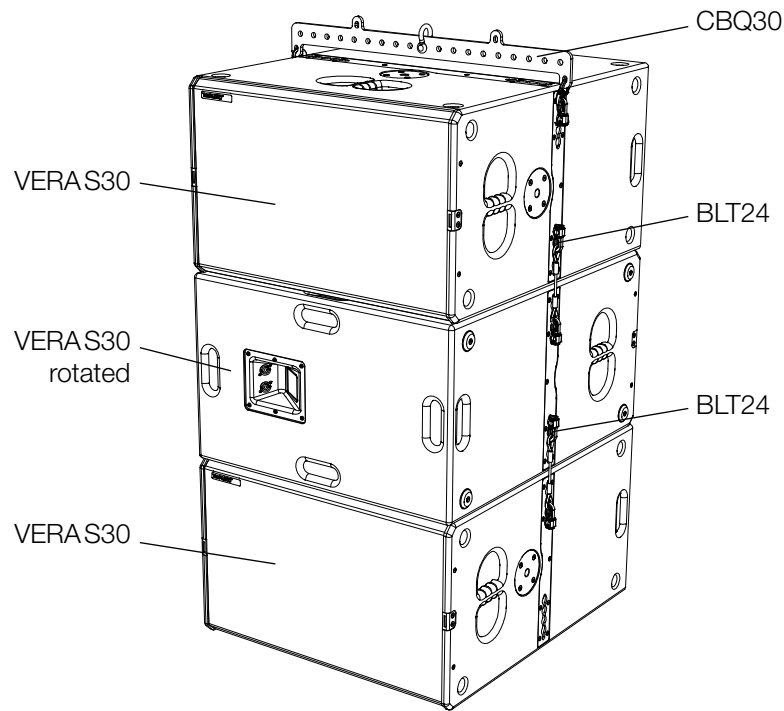

Figure 4.4 - System setup CBQ30 with VERAS30 loudspeaker - cardioid mode

## 5. Transport and storage



Ensure that the surface of the cradle bar for flying is not damaged during transport and storage. Moisture may penetrate where steel surfaces are exposed by scratches and result in corrosion.

This is why the product should be transported in a safe, careful, dry and largely dust-free manner.

The following accessory parts for the cradle bar for flying are available from TWAUDIÖ:

- Shackle SK10
- Boxlink connector wire rope BLT24
- Suspension chain ASK4

The original packaging is unsuitable as permanent storage and transport packaging.

## 6. CE Conformity Declaration

Copy and translation of the original CE Conformity Declaration:



We hereby declare that the below-referenced components by virtue of their design and construction, and in the configuration placed on the market by us, satisfy the safety and health requirements of the applicable EC directives. This declaration becomes invalid in case of modifications that have not been approved by us.

### **This declaration applies to the following components**

- CBQ30

as well as all model variants based on these, provided that they correspond to the original factory models and have not been technically modified in any way.

### **Applicable directives:**

- 2001/95/EG

### **Applicable national standards and technical specifications:**

- DIN EN 18800
- DIN EN ISO 12100
- DGUV Vorschrift 17 und 18

Berlin, Germany, January 1st, 2021

A handwritten signature in black ink, appearing to read 'Wüstner', is written above the printed name 'Bernhard Wüstner'.

Bernhard Wüstner

## 7. Disposal

If you have any question regarding the disposal of used devices, please contact us under the following telephone number:

+49 (0) 71 41 - 48 89 89 0

In countries outside of the European Union, comply with local regulations.

TWAMBO GmbH  
Karl-Hofer-Str. 42  
14163 Berlin  
Germany

Phone: + 49 (0) 71 41-48 89 89 0  
Fax: + 49 (0) 71 41-48 89 89 99  
E-Mail: [info@twaudio.de](mailto:info@twaudio.de)  
WWW: [www.twaudio.de](http://www.twaudio.de)