

APL-output wiring

Operation manual

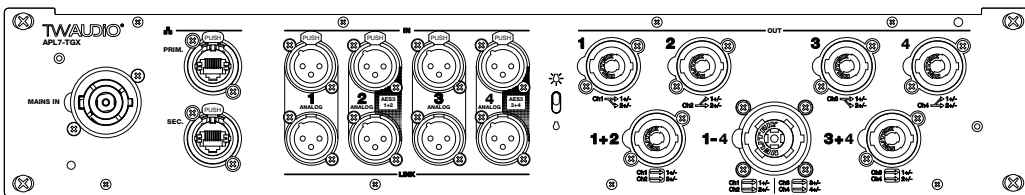
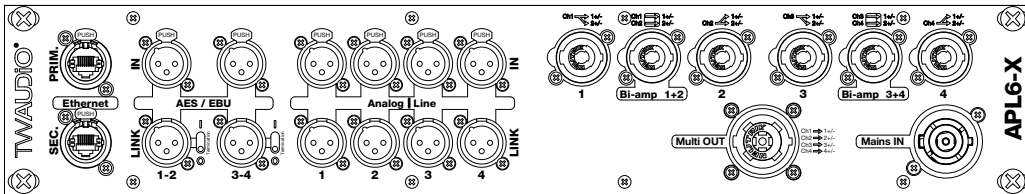
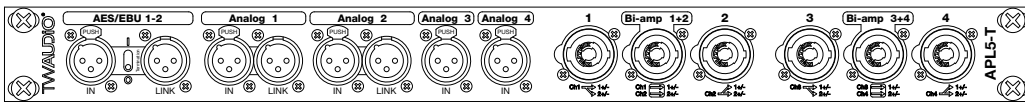
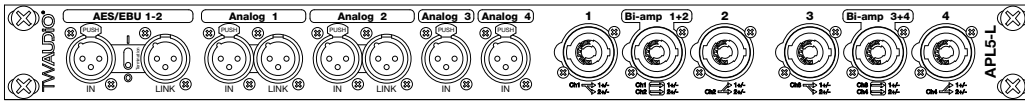

Introduction

Thank you for choosing a high-quality product “MADE IN GERMANY” from the brand TWAUDIÖ.

The TWAUDIÖ SYSRACKS are designed for the operation of small to medium-sized sound reinforcement systems and enable fast and flexible cabling of several racks.

Each SYSRACK has four freely configurable amplifier channels, which are realized either by one four-channel power amplifier or by two two-channel power amplifiers. Furthermore, each rack also contains a APL connection panel, that provides either some or all of the amplifier’s connectors and additional link sockets at the front of the SYSRACK.

This manual describes the output wiring of the SYSRACKS with the connection panels. Starting with APL5, all connection panels follow a uniform standard using 4-pin speakON® NL4 and 8-pin speakON® NL8 sockets.

The input routing may vary depending on the amplifier platform and model used. For further information on input cabling, please refer to the additional product product documentation or contact the TWAUDIÖ support department.

If you lend your product to another party, inform that party of the safety-related operating procedures and hand over this assembly guide. If you require additional copies of this manual, you can obtain them free of charge from TWAUDIÖ or download them from www.twaudio.de

Instructions in this user manual

Strictly adhere to the instructions contained in this operating manual that are marked as follows:



This symbol in combination with the signal word “Warning” identifies a potentially hazardous situation. Failure to comply with this safety instruction can lead to serious injury or even death.



This symbol in combination with the signal word “Warning” identifies a potentially hazardous situation for persons with a pacemaker. Failure to comply with this safety instruction can lead to serious injury or even death.



This symbol in combination with the signal word “Caution” identifies a potentially hazardous situation. Failure to comply with this safety instruction can lead to light or moderate injury.



This symbol in combination with the signal word “Note” identifies a potentially hazardous situation. Failure to comply with this safety instruction can lead to product damage.



This symbol in combination with the signal word “Tip” identifies additional information or notes that will simplify working with TWAUDIO products on the basis of practical experience.

Notes on the products

**Read manual
before use!**

Before using the device, carefully read the operating manual and keep it with the APL connection panels.

General information

Operation manual APL-output wiring: OM-APL
Version 2.4 en, 07/2024
© by TWAMBO 2024; all rights reserved.

All information contained in this operating manual was correct to the best of our knowledge at the time of printing.

Quality warranties or assurance of suitability for a certain type of use based on the technical specifications, dimensions and weights are not granted by TWAMBO.

TWAMBO also shall not assume liability for any secondary damage (property damage and/or personal injury) nor for the failure to comply with this operating manual!

TWAMBO reserves the right to update this document based on recent developments.

TWAMBO GmbH
Karl-Hofer-Str. 42
14163 Berlin
Germany

Phone : + 49 (0) 71 41-48 89 89 0
Fax: + 49 (0) 71 41-48 89 89 99
E-Mail: info@twaudio.de
WWW: www.twaudio.de

Content

1. Safety Intended use	5
2. Technical data	6
2.1 APL5 connection panel.....	6
2.2 APL6-X connection panel	8
2.3 APL7-TGX connection panel	9
3. Commissioning.....	10
3.1 Loudspeaker connection	10
3.2 Output channel assignment	11
3.3 Amplifier configuration	12
4. Wiring possibilities	13
4.1 Cabling single-channel, passive loudspeakers	13
4.2 Cabling two-channel, passive loudspeaker (biamp).....	14
4.3 Cabling of one- and two-channel passive systems	16
4.4 Cabling two-channel subwoofer configuration	18
4.5 Amplifier system configuration with two-channel passive subwoofer.....	20
4.6 Cabling single-channel passive top unit with multi-out	21
4.7 Cabling two-channel passive top with multi-out	22
5. Transport and Storage.....	23
6. CE Conformity Declaration.....	24
7. Disposal	25

1. Safety | Intended use

Please adhere to the following safety instructions to avoid risks when using accessories.

The APL connection panels are developed for use in professional sound systems. The connection panels may only be used by trained and qualified personnel.

Note the operating modes described in this operating manual. Other uses are not permissible.

Damage caused by improper use is not covered by TWAMBO.



Before every operation, check the scope of delivery of the APL connection panels for its completeness and ensure that all parts are in perfect condition.



This operation manual describes how to use the APL connection panels correctly. Any other use shall be deemed improper and may result in damage or even injury.

Modifications or alterations to individual parts of the APL connection panels are not permitted! Danger to life!



The APL connection panels is designed both for indoor and outdoor use. Keep the devices away from water!

The panels are not protected against dripping, spraying or splashing water, IP20.



The APL connection panels may only be used by trained and qualified personnel. Personnel must check the APL connection panels for suitability before each use.



The APL connection panels must be taken out of operation immediately as soon as visible damage to the parts can be seen.



When moving (assembling, dismantling, maintaining) the APL connection panels, ensure sufficient space to prevent collisions with other objects.



Do not squeeze or twist the electrical cables of the APL connection panels during the installation! The respective national electrotechnical rules and regulations are applicable.

2. Technical data

2.1 APL5 connection panel

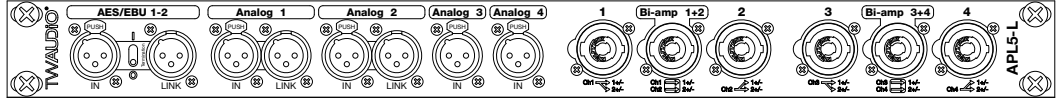

Figure: 2.1.1 - APL5-L

Usage	SYSRACK-L
Application	for front mounting in Rack3L in combination with a power amplifier of the Lab Gruppen PLM+ series, PLM+12K44 as standard
Dimensions	19" 1U
Input	1x AES/EBU IN + LINK with switchable termination 4x analog IN + 2 LINK
Output	6x speakON® NL4 OUT

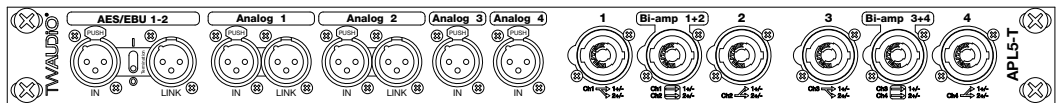

Figure: 2.1.2 - APL5-T

Usage	SYSRACK-T
Application	for front mounting in Rack3M in combination with two Powersoft T602 amplifiers as standard
Dimensions	19" 1U
Input	1x AES/EBU IN + LINK with switchable termination 4x analog IN + 2 LINK
Output	6x speakON® NL4 OUT

The APL5-L and APL5-T connection panels are shown in abbreviated form in the following sections. The internal wiring of the outputs of both panels is equivalent, which is why only one representative example is shown.

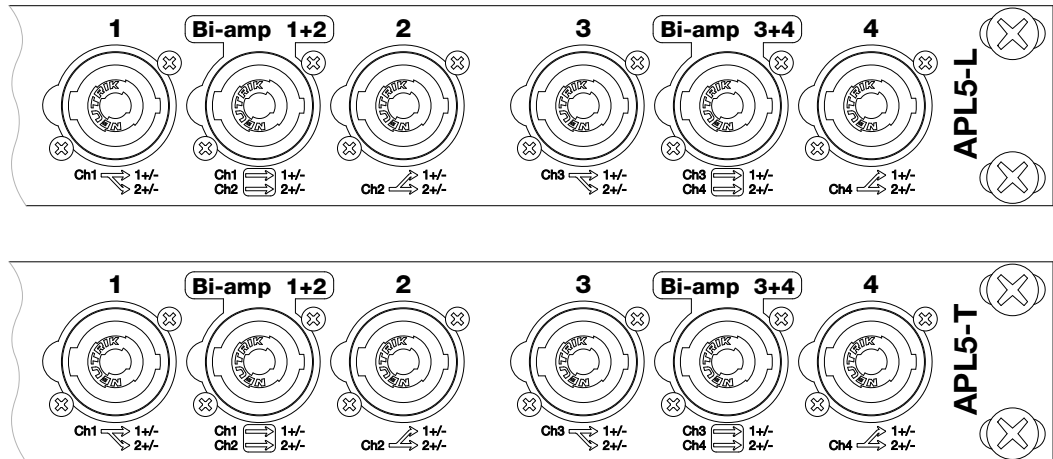

Figure: 2.1.3 - simplified representation APL5-L and APL5-T

2.2 APL6-X connection panel

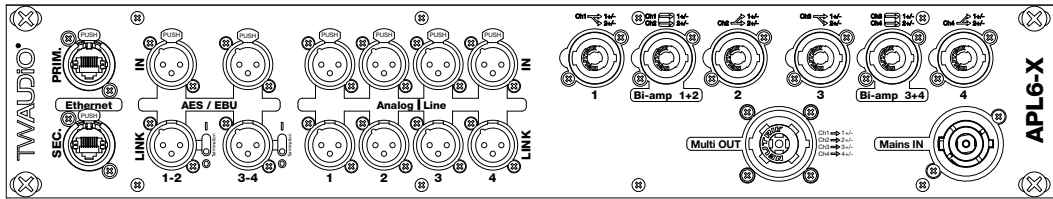

Figure: 2.2.1 - APL6-X

Usage	SYSRACK-X
Application	for front mounting in Rack3X in combination with a Powersoft X4 power amplifier
Dimensions	19" 2U
Mains in	1x powerCON® 32A IN
Network	2x ethercon®/RJ45
Input	2x AES/EBU IN + 2 LINK with switchable termination 4x analog IN + 4 LINK
Output	1x speakON® NL8 OUT 6x speakON® NL4 OUT

The APL6-X connection panel is shown in abbreviated form in the following sections.

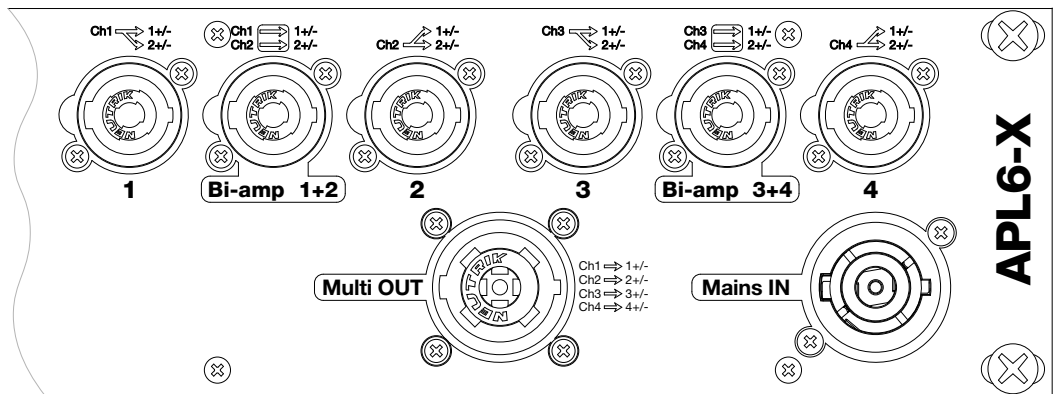

Figure: 2.2.2 - simplified representation APL6-X

2.3 APL7-TGX connection panel

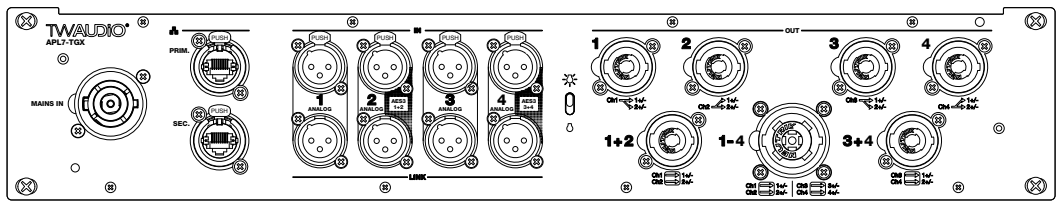

Figure: 2.3.1 - APL7-TGX

Usage	SYSRACK-TGX
Application	for front mounting in Rack4-TGX in combination with a power amplifier of the Dynacord TGX series, TGX10 as standard
Dimensions	19" 2U
Mains in	1x powerCON® 32A IN
Network	2x ethercon®/RJ45
Input	2x AES3 in combination and alternative use with 4x analog IN & LINK via XLR
Output	1x speakON® NL8 OUT 6x speakON® NL4 OUT

The APL7 connection panel is shown in abbreviated form in the following sections.

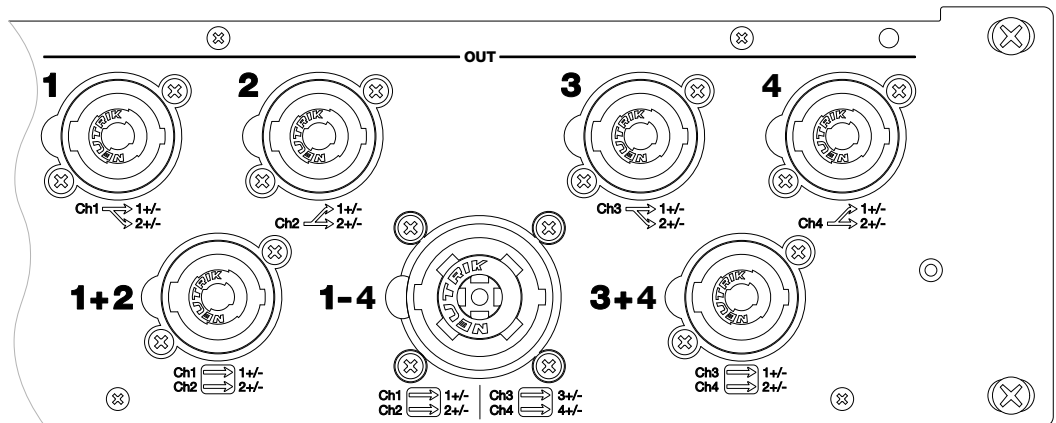

Figure: 2.3.2 - simplified representation APL7-TGX

3. Commissioning

The following abbreviations are used in this document:

CH	Channel
FR	Full range / Broadband / Entire playback spectrum
FS	Front speaker, a forward-facing speaker in a cardioid configuration
GF	Gradient front, a forward-facing speaker in a cardioid configuration
GR	Gradient rear, a rear-facing speaker in a cardioid configuration
HF	High frequency / high-frequency spectrum
LF	Low frequency / low-frequency spectrum
RS	Rear speaker, a rear-facing speaker in a cardioid configuration
SB	Subwoofer



NOTE

The channel designations RS and GR describe the same signal output. The same applies to the channel designations FS and GF.

To improve readability, multiple designations has been omitted and only the channel designations GR and GF have been used.

3.1 Loudspeaker connection

The loudspeakers in the TWAUDIÖ product portfolio have several 4-pin NL4 connection sockets which are wired in parallel inside the speaker. Depending on the system configuration, all transmitted signals can be forwarded or received.

TWAUDIÖ's product portfolio includes single-channel passive tops and subwoofers that require a dedicated amplifier channel as well as two-channel (biamp) tops and subwoofers that require two dedicated amplifier channels.

Depending on the speaker type, the speaker drivers use the pin 1+/- (top) or 2+/- (sub) or both pins of the four-wire NL4 connection.

The following table compares the internal speaker cabling of the different models.

	Passive	Biamp
Top	FR: Pin 1+/- (Special case: T24N, C12, C15)	HF: Pin 1+/- LF: Pin 2+/-
Sub	SB: Pin 2+/- (Special case: B15, B10)	RS/GF: Pin 1+/- FS/GF: Pin 2+/- (Special case: BSX)









Some products offer a passive and a biamp operating mode, e.g. T24N, C12, C15, VERA10. To avoid damage, be sure to load the correct preset for the operating mode in use!

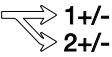
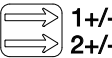
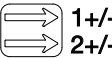
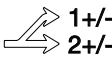

The B10 and B15 loudspeakers have the option of an internal crossover to separate the high and low frequencies. Depending on the setting on the crossover, the drivers sometimes use different wire pairs. Please contact the [TWAUDIÖ support department](#) for further information on configuration.

3.2 Output channel assignment

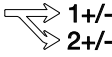
The following table describes the assignment of the output sockets with the signals of the amplifier channels and assigns them to the icons of the APL connection fields.

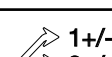
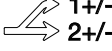
OUT	Connector type	Pin 1+/-	Pin 2+/-	Pin 3+/-	Pin 4+/-
Ch1  1+/- 2+/-	NL4	CH1	CH1		
Ch1  1+/- Ch2  2+/-	NL4	CH1	CH2		
Ch2  1+/- 2+/-	NL4	CH2	CH2		
Ch1  1+/- Ch2  2+/- Ch3  3+/- Ch4  4+/-	NL8	CH1	CH2	CH3	CH4
Ch3  1+/- 2+/-	NL4	CH3	CH3		
Ch3  1+/- Ch4  2+/-	NL4	CH3	CH4		
Ch4  1+/- 2+/-	NL4	CH4	CH4		

The following table describes the color coding of the pins of NL4 and NL8 connector types used by TWAUDIÖ.

Connection type: NL8		Connection type: 1. NL4		Connection type: 2. NL4	
Pin	Color	Pin	Color	Pin	Color
1+	red	1+	red		
1-	black	1-	black		
2+	white	2+	white		
2-	blue	2-	blue		
3+	yellow			1+	yellow
3-	purple			1-	purple
4+	green			2+	green
4-	grey			2-	grey

3.3 Amplifier configuration

The amplifier configurations described in this document do not correspond to the actual designations of the speaker equalisations (presets) provided by TWAUDIÖ.

The information only provides an indication of which preset must be assigned to the corresponding channel. The preset selection depends on the selected system configuration and speaker application.

For further information on preset selection and amplifier configuration, please refer to the additional product documentation or contact the [TWAUDIÖ support department](#).

4. Wiring possibilities

4.1 Cabling single-channel, passive loudspeakers

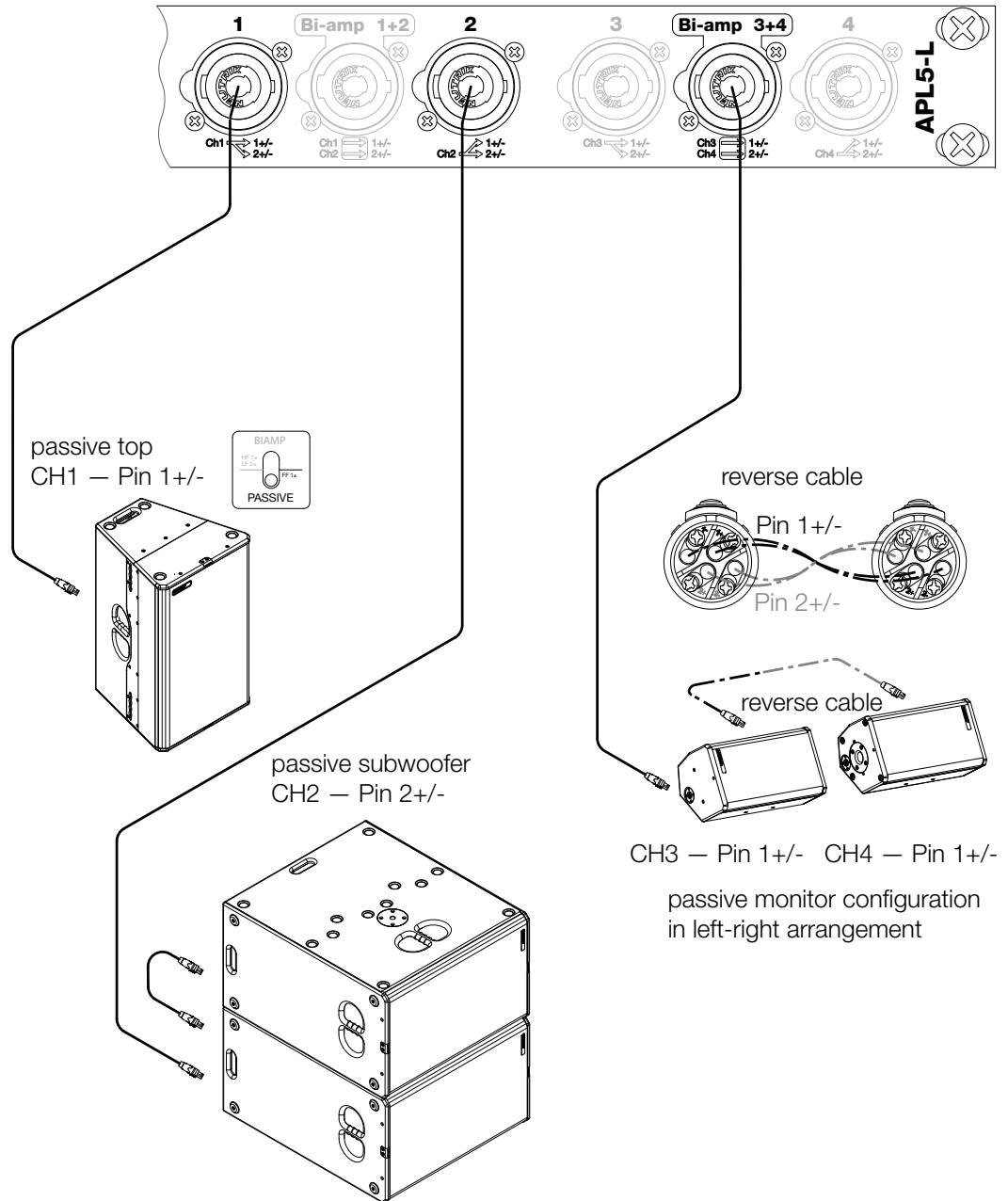

Figure: 4.1 - Cabling single-channel passive loudspeakers

Amplifier configuration of the example system:

CH1	CH2	CH3	CH4
T24Npa	BS30	M8	M8



If you use the BIAMP output of the amplifier or the patch panel, an additional pin reverse cable may be required.

4.2 Cabling two-channel, passive loudspeaker (biamp)

The loudspeaker requires two amplifier channels. The treble drivers of two-channel biamp tops are electrically connected to pin 1+/- and the bass or mid-range drivers to pin 2+/-.



When using two-channel biamp tops, always ensure that you use the speakON® connector of one of the biamp outputs on the connection panel.

Ch1 → 1+/- Ch3 → 1+/-
 Ch2 → 2+/- Ch4 → 2+/-

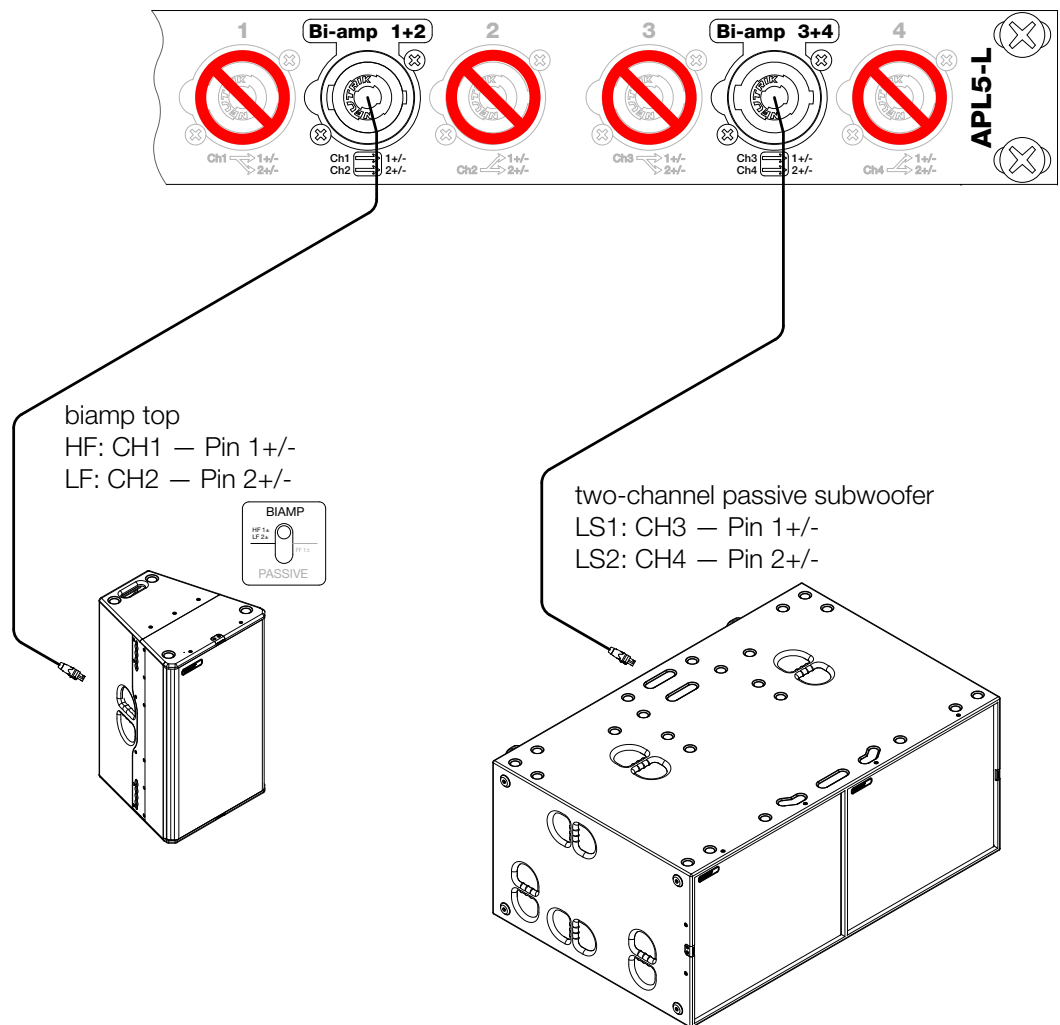

Figure: 4.2.1 - Cabling biamp loudspeakers

Amplifier configuration of the example system:

CH1	CH2	CH3	CH4
T24Nbi_HF	T24Nbi_LF	BSXLS1	BSXLS2



Some products offer a passive and a biamp operating mode, e.g. T24N, C12, C15, VERA10. To avoid damage, be sure to load the correct preset for the operating mode in use!

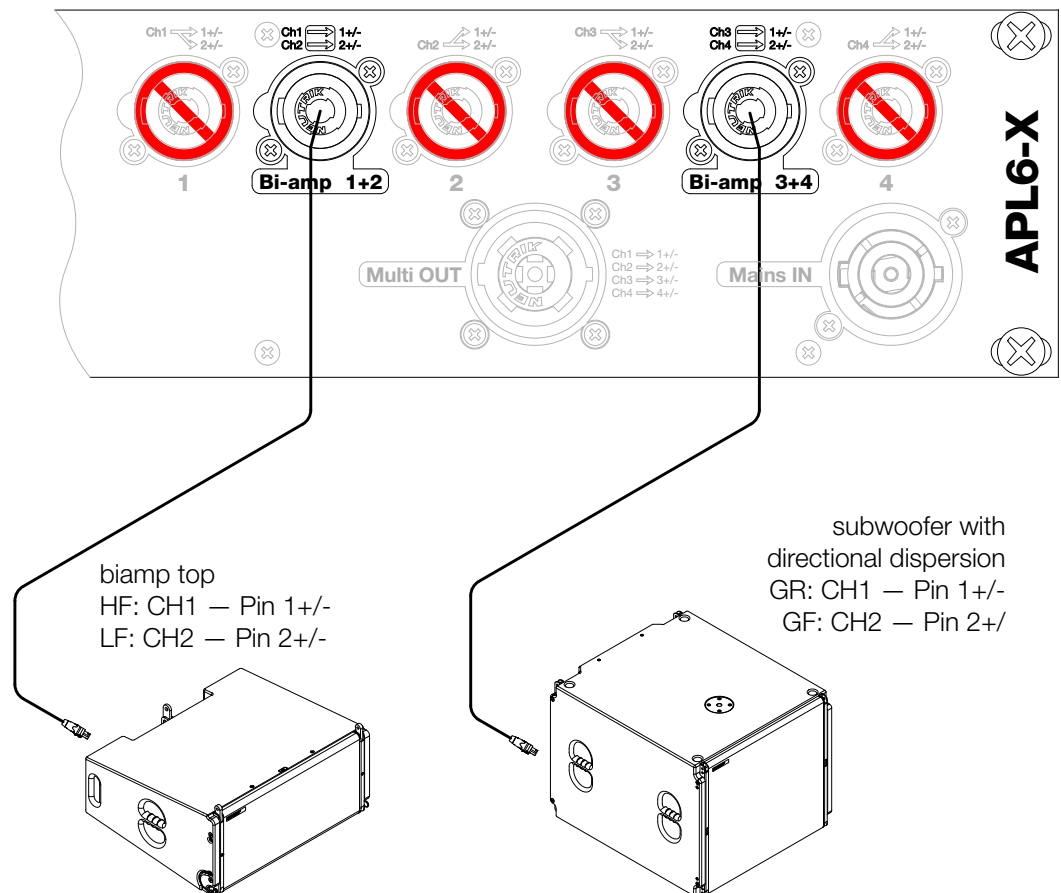

Figure: 4.2.2 - Cabling biamp loudspeakers

Amplifier configuration of the example system:

CH1	CH2	CH3	CH4
VERA36_HF	VERA36_LF	VERA S33_GR	VERA S33_GF

4.3 Cabling of one- and two-channel passive systems

Two-channel passive systems consist of a single-channel passive top and single-channel subwoofer on each side, driven by two dedicated amplifier channels. Therefore, four amplifier channels are required for the overall L/R system.

As single-channel passive tops are electrically connected to pin 1+/-, it is recommended to load these presets into odd-numbered amplifier channels.

As single-channel passive subwoofers are electrically connected to pin 2+/-, it is recommended to load these presets into even amplifier channels. This results in simple cabling with the patch panels of the TWAUDIO amplifier racks.

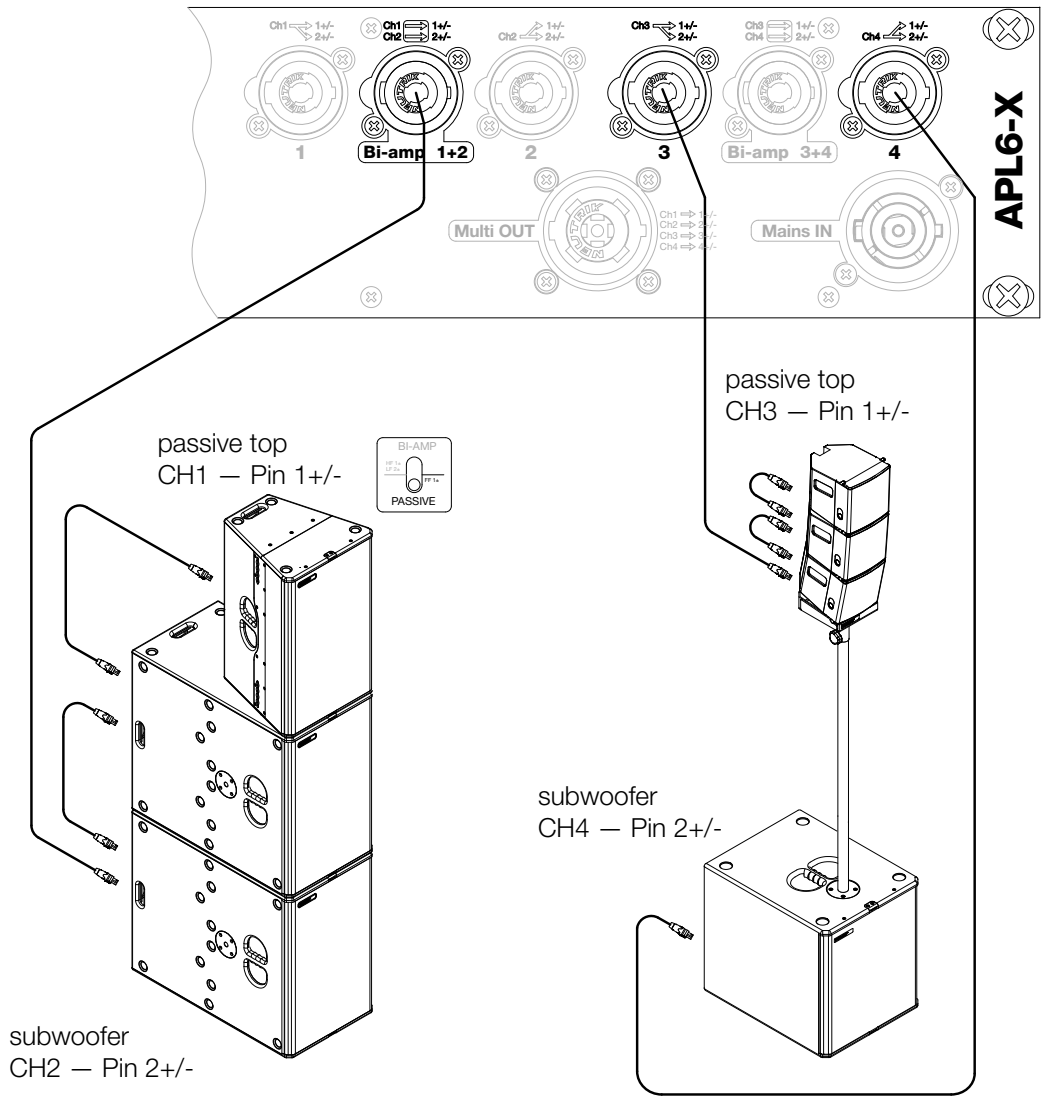

Figure: 4.3.1 - Cabling two-channel passive systems

Amplifier configuration of the example system:

CH1	CH2	CH3	CH4
T24Npa	BS30	ELLA6	BS15 active

Single-channel passive systems consist of a top unit and a subwoofer whose frequency ranges are separated by an internal passive crossover, usually in the subwoofer. This means that two amplifier channels are required for the overall L/R system.

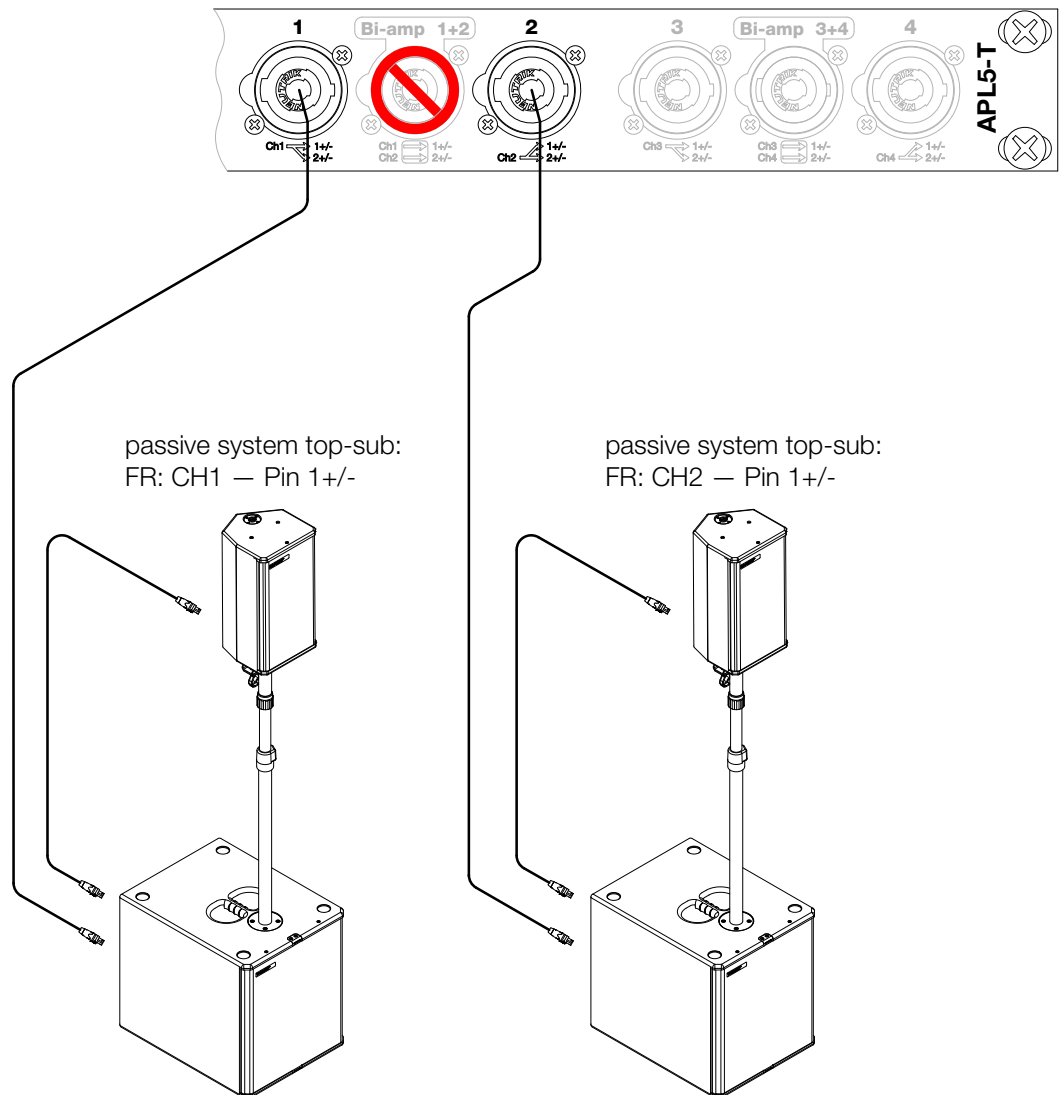

Figure: 4.3.2 - Cabling single-channel passive systems

Amplifier configuration of the example system:

CH1	CH2	CH3	CH4
B15pM8	B15pM8		



To ensure correct and safe operation of these systems, adjustments must be made to the passive crossover. Please contact the [TWAUDI support department](#) for further information on configuration.

4.4 Cabling two-channel subwoofer configuration

When using a speaker configuration for directional subwoofer arrangements (cardioid stacks), two independent amplifier channels are required. The APL7 connection panels offer two options for cabling the configurations.

Presets for rear-facing subwoofers in cardioid stacks are labeled GR in the system controller, and presets for front-facing subwoofers are labeled GF. Please contact the [TWAUDIÖ support department](#) for further information on the configuration and structure of cardioid stacks.

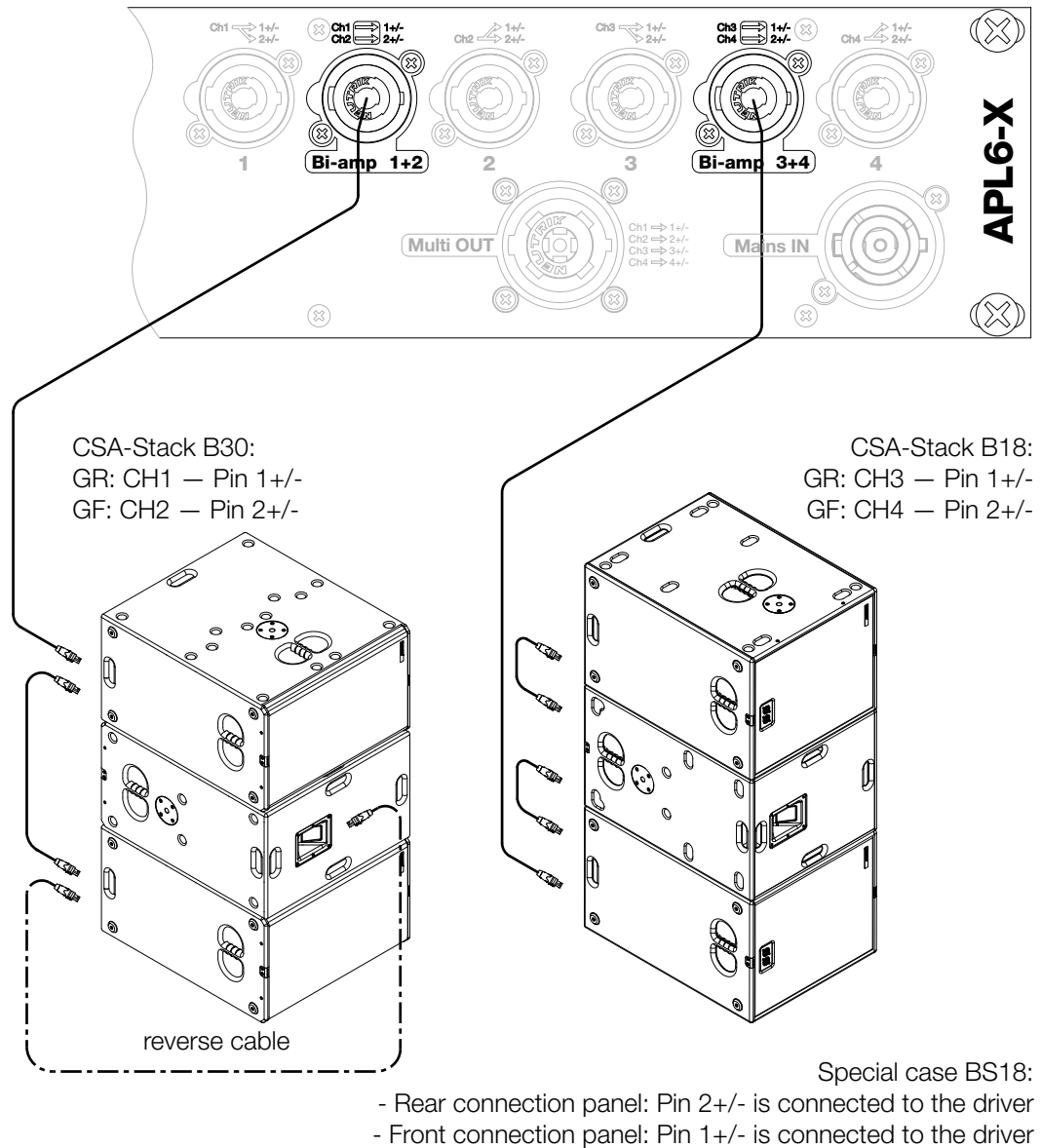

Figure: 4.4.1 - Cabling a two-channel subwoofer configuration with directional radiation (cardioid stack)



If you use the biamp output of the amplifier or the patch panel, an additional pin reverse cable may be required.

Amplifier configuration of the example system:

CH1	CH2	CH3	CH4
BS30cardio_GR	BS30cardio_GF	BS18cardio_GR	BS18cardio_GF

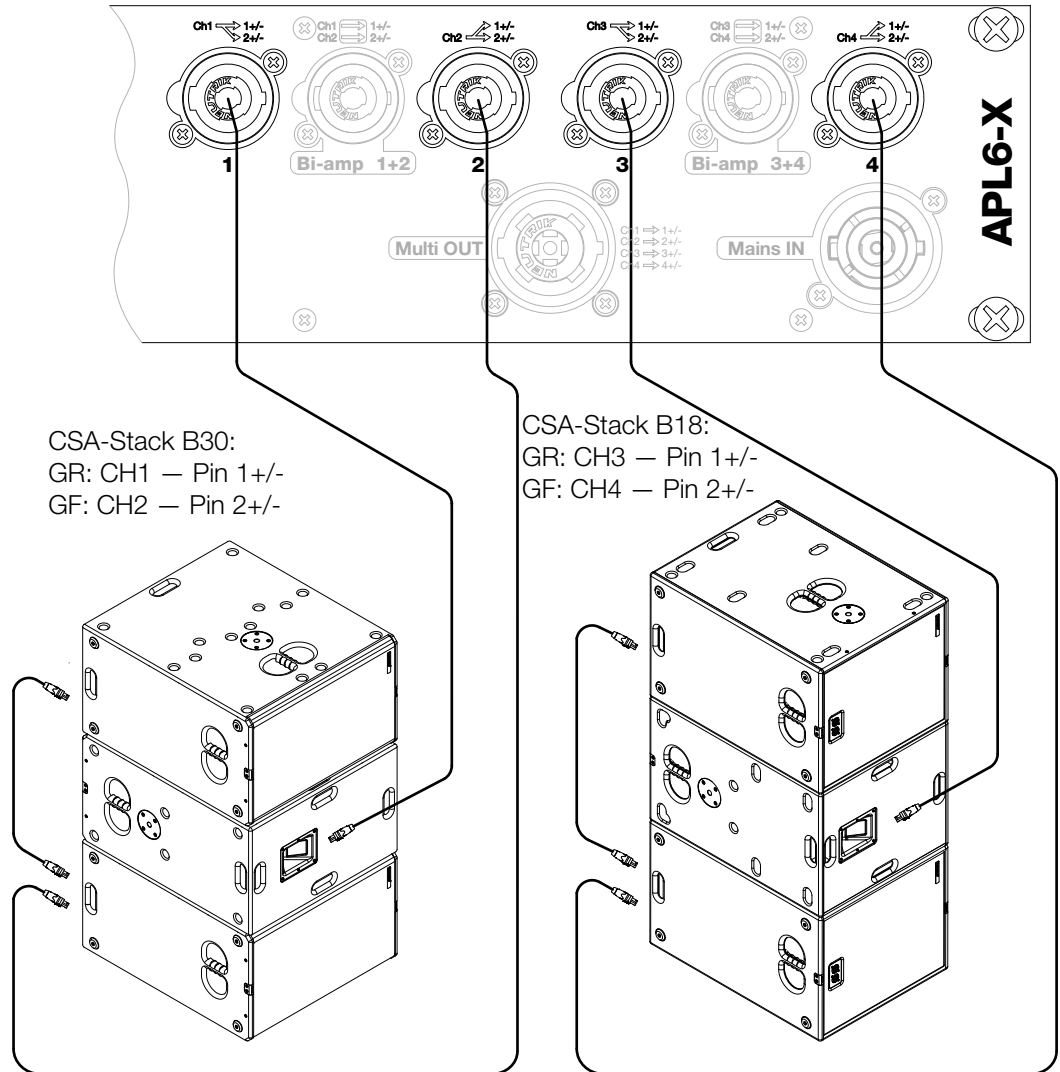

Special case BS18:

- Rear connection panel: Pin 2+/- is connected to the driver
- Front connection panel: Pin 1+/- is connected to the driver

Figure: 4.4.2 - Cabling a two-channel subwoofer configuration with directional radiation (cardioid stack)

Amplifier configuration of the example system:

CH1	CH2	CH3	CH4
BS30cardio_GR	BS30cardio_GF	BS18cardio_GR	BS18cardio_GF

4.5 Amplifier system configuration with two-channel passive subwoofer

A four-channel overall system can also be realized with a two-channel subwoofer. To do this, the subwoofers are connected in parallel to two amplifier channels. The single-channel, passive tops each use one amplifier channel.

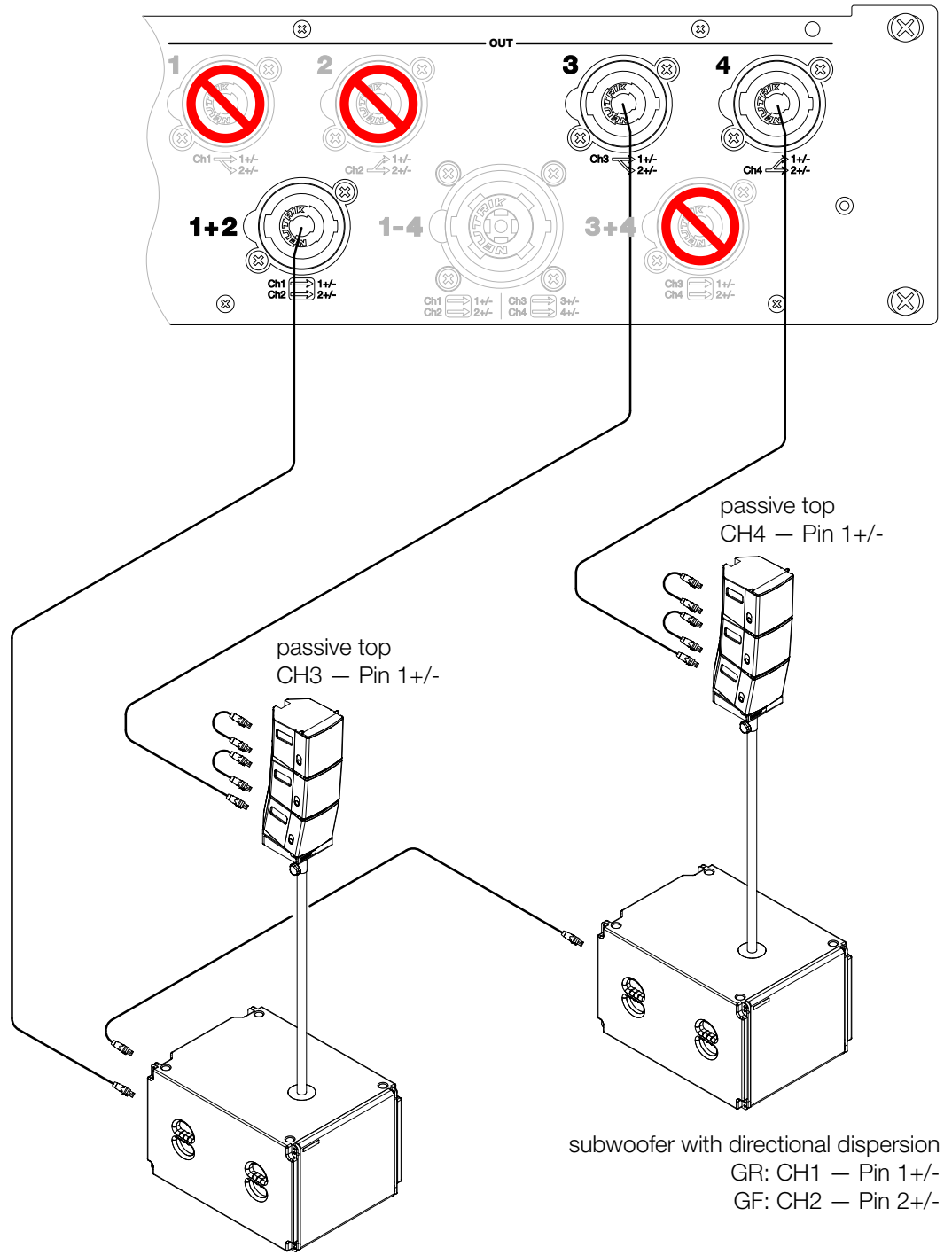

Figure: 4.5 - Amplifier system configuration with two-channel passive subwoofer

Amplifier configuration of the example system:

CH1	CH2	CH3	CH4
VS32_GR	VS32_GF	ELLA6	ELLA6

4.6 Cabling single-channel passive top unit with multi-out

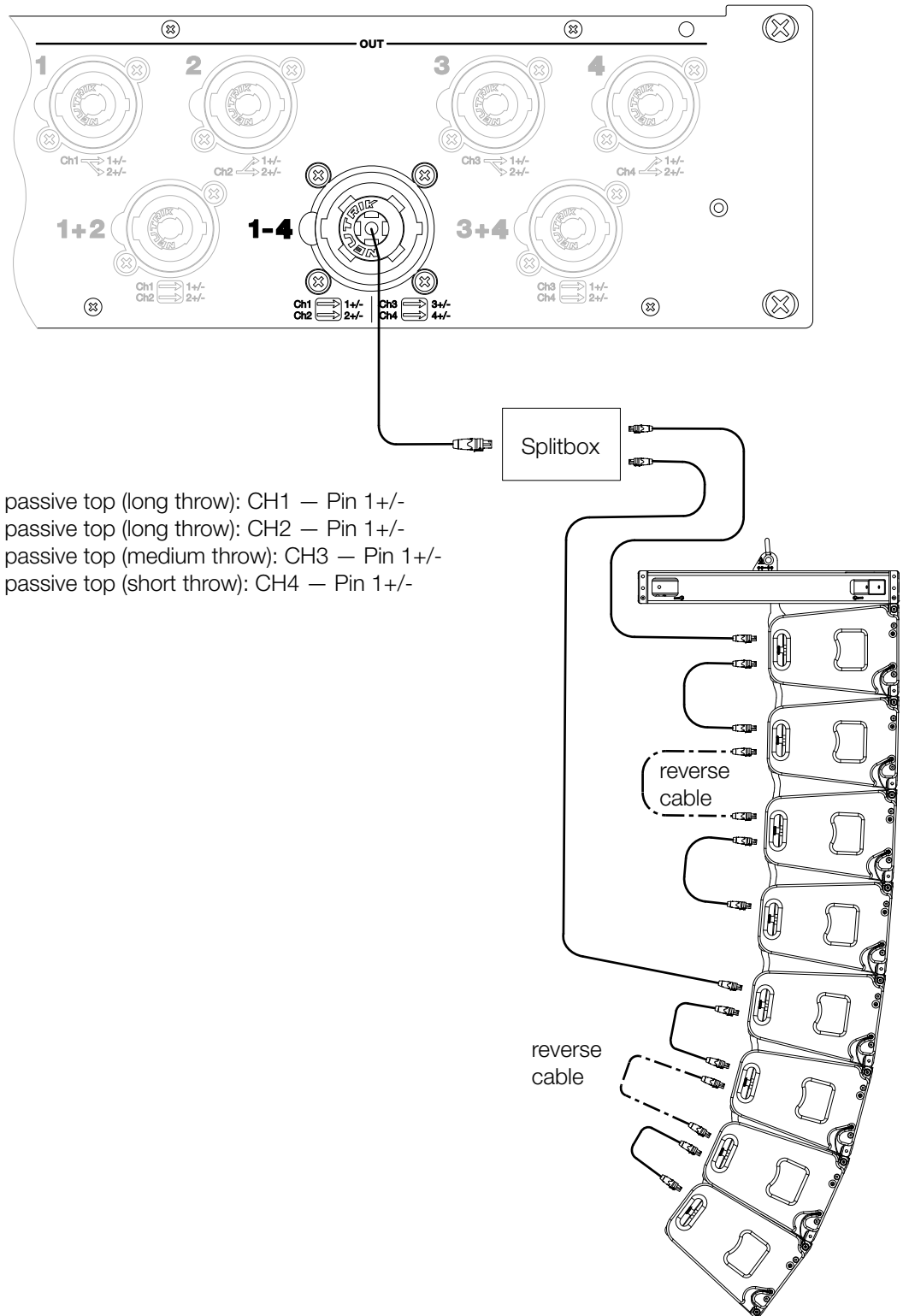

Figure: 4.6 - Cabling two-channel passive top with multi-out

Amplifier configuration for the example system:

CH1	CH2	CH3	CH4
VERA20	VERA20	VERA20	VERA20

4.7 Cabling two-channel passive top with multi-out

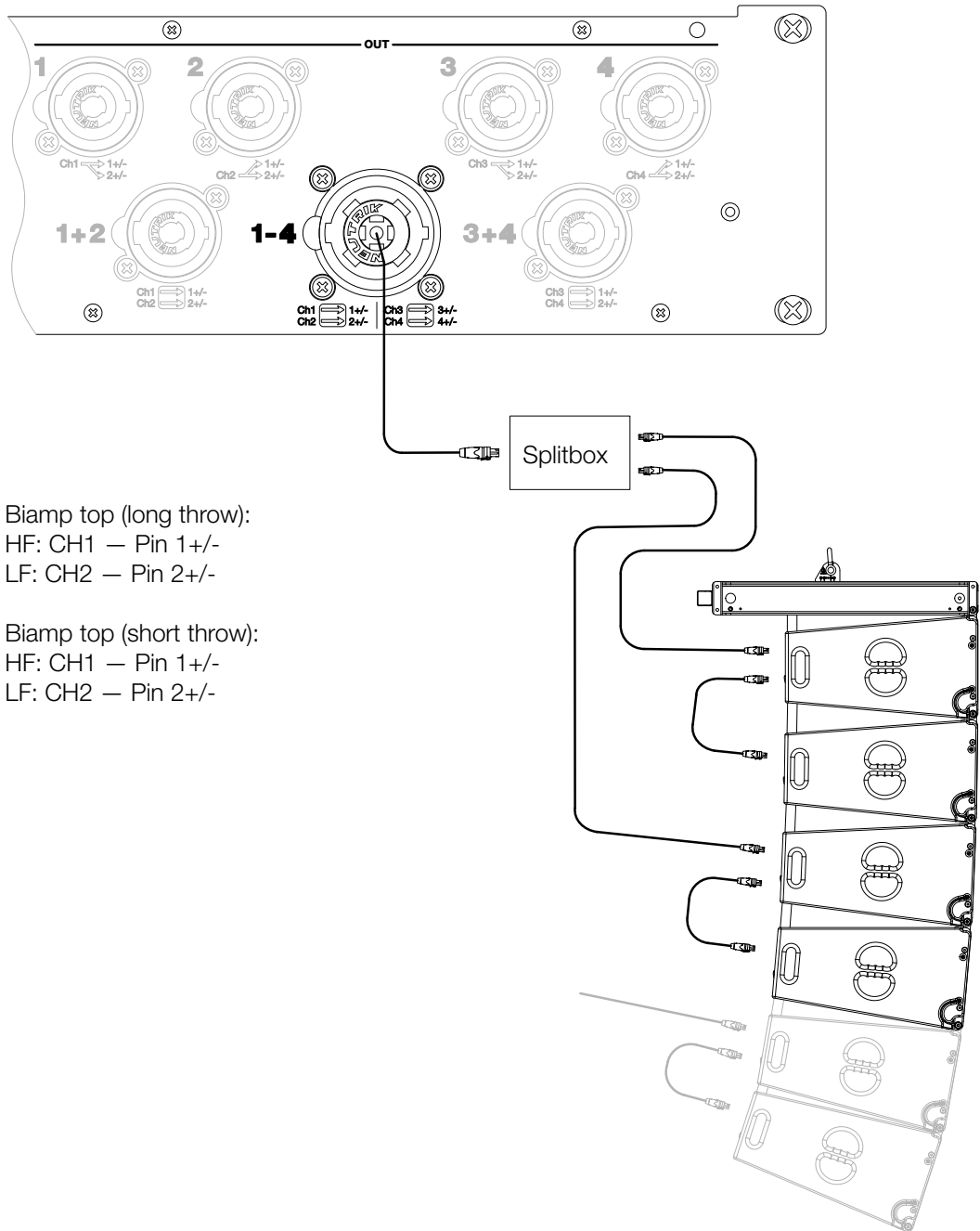

Figure: 4.7 - Cabling two-channel passive top with multi-out

Amplifier configuration for the example system:

CH1	CH2	CH3	CH4
VERA36_HF	VERA36_LF	VERA36_HF	VERA36_LF

5. Transport and Storage



Ensure that the surface of the connection panels are not damaged during transport and storage. Moisture may penetrate where steel surfaces are exposed by scratches and result in corrosion.

This is why the products should be transported in a safe, careful, dry and largely dust-free manner.

The original packaging is unsuitable as permanent storage and transport packaging.

6. CE Conformity Declaration

Copy and translation of the original CE Conformity Declaration:



We hereby declare that the below-referenced components by virtue of their design and construction, and in the configuration placed on the market by us, satisfy the safety and health requirements of the applicable EC directives. This declaration becomes invalid in case of modifications that have not been approved by us.

This declaration applies to the following components

- APL5-L and APL5-T
- APL6-X
- APL7-TGX

as well as all model variants based on these, provided that they correspond to the original factory models and have not been technically modified in any way.

Applicable directives:

- 2001/95/EG
- 2011/65/EU

Applicable national standards and technical specifications:

- DIN EN 18800
- DIN EN ISO 12100
- DGUV Vorschrift 17 und 18
- EN 50581: 2013-02

Berlin, Germany, January 1st, 2021

A handwritten signature in black ink, appearing to read 'Wüstner', written in a cursive style.

Bernhard Wüstner

7. Disposal

It is prohibited to dispose of used electrical equipment with household refuse.



All TWAMBO GmbH products are so-called B2B-products. This means that they are sold by a commercial business to a commercial business. TWAMBO products that bear the trash can symbol shown here may only be disposed of by TWAMBO.

The loudspeaker owner is legally responsible for proper disposal of used devices that do not bear this symbol. This pertains to all products delivered prior to March 29, 2010. Nevertheless, TWAMBO will also be happy to assist you in this case.

If you have any question regarding the disposal of used devices, please contact us under the following telephone number:

+49 (0) 71 41 - 48 89 89 0

Thus, TWAMBO is in strict compliance with the Waste Electrical and Electronic Equipment Directive (2012/19/EU) for the protection of our environment.

TWAMBO is registered under the following WEEE-reg.-no. with the German National Register EAR as a B2B-manufacturer and distributor of electrical devices:

DE93295191

In countries outside of the European Union, comply with local regulations.

TWAMBO GmbH
Karl-Hofer-Str. 42
14163 Berlin
Germany

Phone: + 49 (0) 71 41-48 89 89 0
Fax: + 49 (0) 71 41-48 89 89 99
E-Mail: info@twaudio.de
WWW: www.twaudio.de