

QBM10

**Assembly
Instructions**

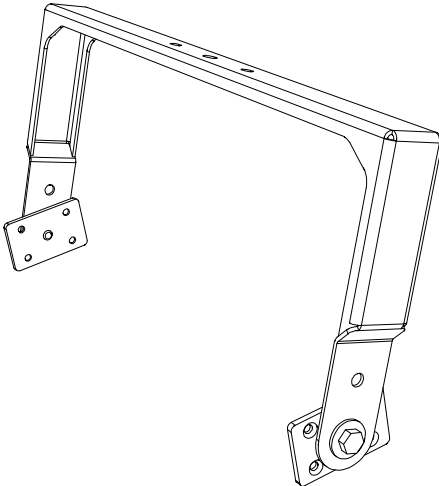

Introduction

Thank you for choosing a high-quality product “MADE IN GERMANY” from the brand TWAUDIÖ.

The swivel bracket QBM10 is an accessory for the M10 loudspeaker.

It is characterized by a subtle look, a remarkable size to weight ratio and ease of use.

If you lend your product to another party, inform that party of the safety-related operating procedures and hand over this assembly guide. If you require additional copies of this manual, you can obtain them free of charge from TWAUDIÖ or download them from www.twaudio.de

Instructions in this user manual

Strictly adhere to the instructions contained in this operating manual that are marked as follows:



This symbol in combination with the signal word “Warning” identifies a potentially hazardous situation. Failure to comply with this safety instruction can lead to serious injury or even death.



This symbol in combination with the signal word “Caution” identifies a potentially hazardous situation. Failure to comply with this safety instruction can lead to light or moderate injury.



This symbol in combination with the signal word “Note” identifies a potentially hazardous situation. Failure to comply with this safety instruction can lead to product damage.



This symbol in combination with the signal word “Tip” identifies additional information or notes that will simplify working with TWAUDIÖ products on the basis of practical experience.

Notes on the products

**Read manual
before use!**

Before using the device, carefully read the assembly instructions and keep it with the QBM10 swivel bracket.

General information

Assembly instructions: OM-QBM10
Version 2.1 en, 11/2023
© by TWAMBO 2023; all rights reserved.

All information contained in this operating manual was correct to the best of our knowledge at the time of printing.

Quality warranties or assurance of suitability for a certain type of use based on the technical specifications, dimensions and weights are not granted by TWAMBO.

TWAMBO also shall not assume liability for any secondary damage (property damage and/or personal injury) nor for the failure to comply with this operating manual!

TWAMBO reserves the right to update this document based on recent developments.

TWAMBO GmbH
Karl-Hofer-Str. 42
14163 Berlin
Germany

Phone : + 49 (0) 71 41-48 89 89 0
Fax: + 49 (0) 71 41-48 89 89 99
E-Mail: info@twaudio.de
WWW: www.twaudio.de

Content

1. Safety Intended use.....	5
2. Overview	7
2.1 Components	7
3. Technical data	8
3.1 Data sheet.....	8
4. Commissioning.....	9
4.1 Setup	9
4.2 Needed tools for setup	9
4.3 Wind load.....	9
4.4 Assembly QBM10 to loudspeaker	10
4.4.1 Removing the side countersunk screws.....	10
4.4.2 Assembly QBM10 to M10 loudspeaker	11
4.5 Assembly QBM10 swivel bracket to trusses, ceiling or wall.....	12
4.6 Assembly QBM10 swivel bracket on tripod.....	13
5. Transport and storage	14
6. CE Conformity Declaration.....	15
7. Disposal	15

1. Safety | Intended use

Please adhere to the following safety instructions to avoid risks when using accessories.

The QBM10 swivel bracket was developed for use in professional sound systems. The swivel bracket may only be used by trained and qualified personnel.

Note the operating modes described in this assembly instructions. Other uses are not permissible.

Damage caused by improper use is not covered by TWAMBO.



Before every operation, check the scope of delivery of the QBM10 swivel bracket for its completeness and ensure that all parts are in perfect condition.

The scope of delivery includes specified components. Only use the recommended and certified components.



The QBM10 swivel bracket may only used with the M10 loudspeaker.

This rigging manual describes how to use the QBM10 swivel bracket correctly. Any other use shall be deemed improper and may result in damage or even injury.

Modifications or alterations to individual parts of the QBM10 swivel bracket are not permitted! Danger to life!



The QBM10 swivel bracket is designed both for indoor and outdoor use.



The QBM10 swivel bracket may only be used by trained and qualified personnel. Personnel must check the QBM10 swivel bracket for suitability before each use.



The QBM10 swivel bracket must be taken out of operation immediately as soon as visible damage to the parts can be seen.



Please keep all elements of the QBM10 swivel bracket away from children! The small parts can easily be swallowed and lead to suffocation!



The payload of the QBM10 swivel bracket is designed for one M10 loudspeaker. Do not exceed this payload.



Before mounting the QBM10 swivel bracket check that e.g. ceilings, trusses and tripods are capable of carrying the payload of the components.



Make sure that no water pipes, electrical lines or any other lines are behind the intended place of mounting.



Only use wall plugs and screws which are suitable for the intended mounting and structural fabric. All screws must be set and tightened properly. Ensure that the fixing holes have the correct depth and diameter. Always use all fixing holes.



When moving (assembling, dismantling, maintaining) the QBM10 swivel bracket with M10 loudspeaker, ensure sufficient space to prevent collisions with other objects.



Do not squeeze or twist the electrical cables of the M10 loudspeaker during the installation of the QBM10 swivel bracket! The respective national electrotechnical rules and regulations are applicable.



All screw connections should be checked each time the QBM10 swivel bracket are installed. Tighten all loose screws. If this is no longer possible, the screws must be replaced.

2. Overview

2.1 Components

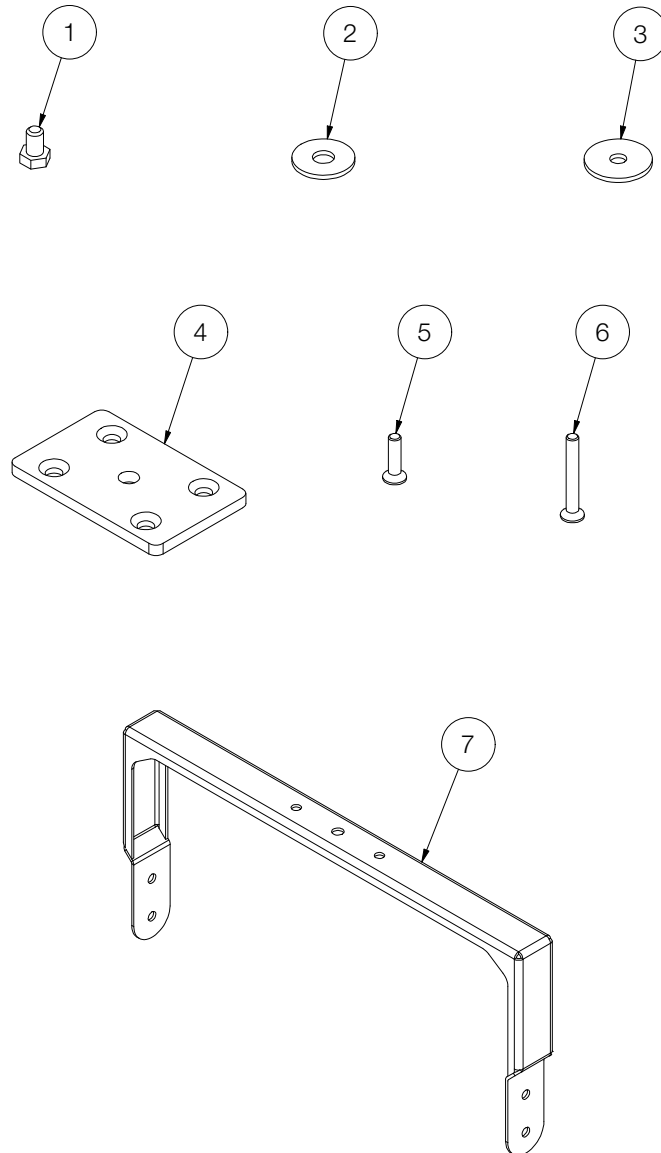

Figure 2.1 - Overview

1.	Hexagon screw M10 x 20.....	2 pieces
2.	Washer (metal).....	2 pieces
3.	Rubber break washer	2 pieces
4.	Adaptor plate	2 pieces
5.	Countersunk screw M5 x 20 black	4 pieces
6.	Countersunk screw M5 x 40 black	4 pieces
7.	Swivel bracket QBM10.....	1 piece

3. Technical data

3.1 Data sheet

Maximum load capacity	1x M10
Dimensions (h x w x d)	255 x 550 x 82mm [10.04 x 21.65 x 3,23in]
Weight	2,5kg [5.5lbs]
Surface	Powder-coated

4. Commissioning

4.1 Setup

The QBM10 swivel bracket is designed for the hanging and stacking operation. TWAUDIÖ provides a wide range of accessories to securely attach the swivel bracket.



Please note that setting up the system structures always requires two persons!



Make sure that all system structures are located on a firm, level surface and that the surface can bear the total weight!



TWAUDIÖ recommends using only the accessories specified by TWAUDIÖ for securing and mounting loudspeakers.

4.2 Needed tools for setup

Have the following tools ready for each setup:

- Open-end wrench SW17
- Torque wrench
- Bit insert for torque wrench: SW3
- Bit insert for torque wrench: TX25

4.3 Wind load



Before setting up the system outdoors, consider unexpected wind conditions at the operation site!

Disassemble your system immediately when wind speeds exceed 8 bft (34 to 40 kn / 62 to 74 kph / 38.5 to 46 mph) and secure the system components!

Make sure that there are no persons in the immediate vicinity of the system structure!



Make sure that the system structures are not operated over the audience at wind speeds in excess of 6 bft (22 to 27 kn / 39 to 49 kph / 24.2 to 30.45 mph) and that there are no persons in the immediate vicinity of the system structure!

4.4 Assembly QBM10 to loudspeaker

4.4.1 Removing the side countersunk screws



Remove the four center countersunk screws on both sides at the M10 loudspeaker as shown in Figure 4.4.1. Keep all eight countersunk screws in a safe place for re-use.



Note that for future uses all eight countersunk screws must be refitted!

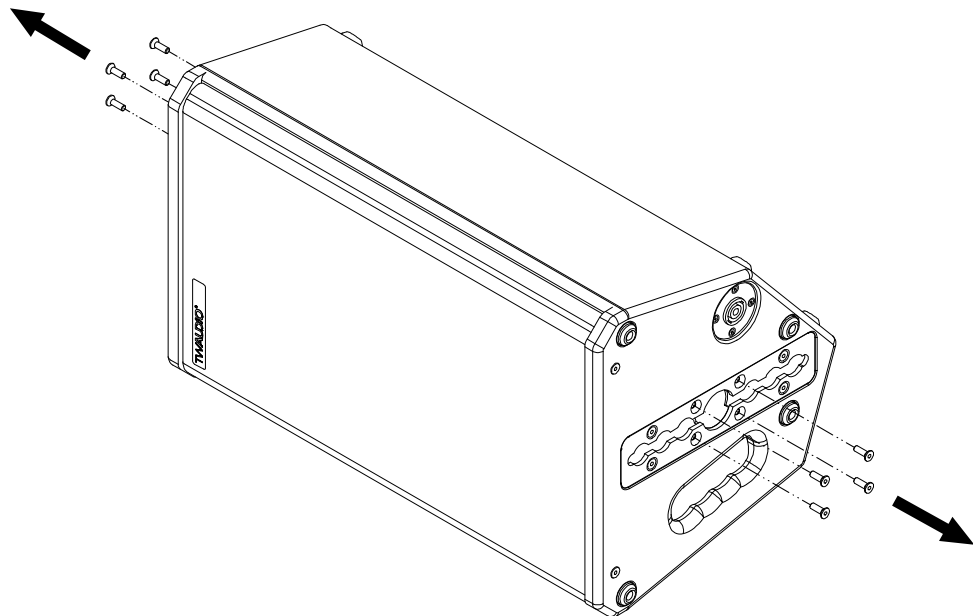

Figure 4.4.1 - Removing the countersunk screws on the M10 loudspeaker

4.4.2 Assembly QBM10 to M10 loudspeaker



Mount positions 1 to 6 (see figure 2.1) on both sides as shown in figure 4.4.2. Note that at pos.7 (see figure 2.1) one of the side holes is used.

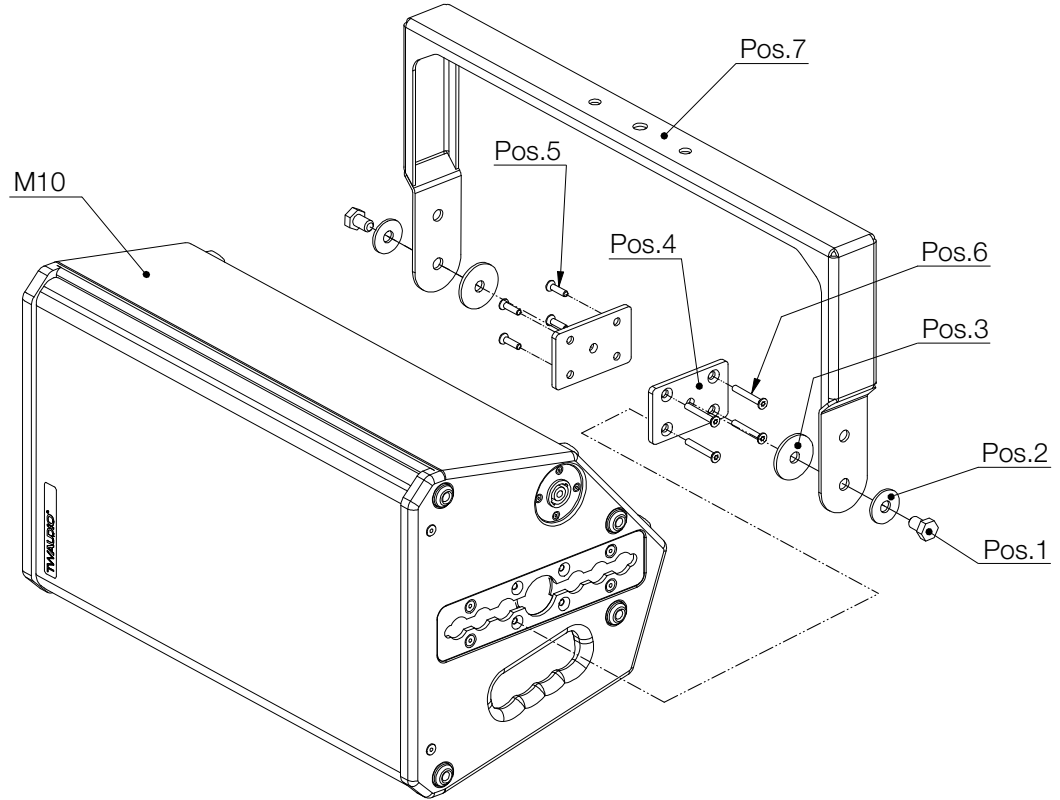

Figure 4.4.2 - Assembly QBM10 to M10 loudspeaker

4.5 Assembly QBM10 swivel bracket to trusses, ceiling or wall



Attach the DHST Doughty Halfcoupler Slimline to the $\varnothing 12.2\text{mm}$ hole located on the crossbar of the QBM10 swivel bracket when using the QBM10 swivel bracket on trusses. Make sure that the connections are set firmly and correctly!



For installation purposes, attach the QBM10 swivel bracket to the ceiling or wall by using all three holes located on the crossbar. Make sure that you use suitable fastening material and that the connections are set firmly and correctly!

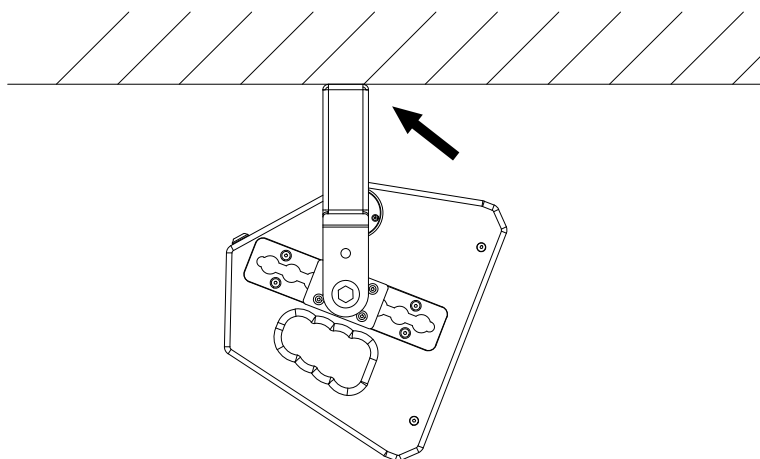

Figure 4.5 - Assembly QBM10 with M10 to ceiling

4.6 Assembly QBM10 swivel bracket on tripod



Mount the M10 loudspeaker with QBM10 swivel bracket and the HSF pole mount flange on the tripod. Make sure that you use suitable fastening material and that the connections are set firmly and correctly!

General safety instructions for setting up on a tripod:



For every system setup on a tripod, use a tripod that is designed according to the total weight.



When setting up a system on uneven surfaces, such as gravel or grass, always put a pressure-resistant surface under all four spindle feet or the tripod legs! Make sure that all four spindle feet or the tripod legs rest completely on the pressure-resistant shims and that the surface can withstand the total weight!

Note that depending on the system design, either the front or rear spindle feet may be able to carry more weight!



Make sure that no one can trip over your system structures, or over individual components! This is especially true for all pressure-resistant shims, tripod legs and bracing ropes!



Any influences on your system setup, such as leaning against objects (or people) and flying objects around, be refrained from!

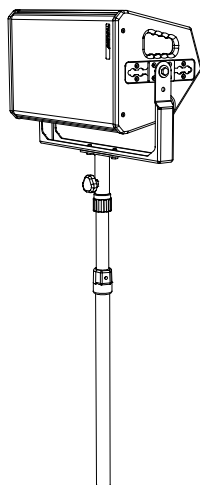

Figure 4.6 - QBM10 with M10 on tripod

5. Transport and storage



When transporting and storing the unit, it is important to ensure that the surface of the swivel bracket are not damaged. Moisture can penetrate where steel surfaces are exposed by scratches and result in corrosion.

In addition, appreciable dust deposits may considerably impair the functionality of a loudspeaker membrane. For this reason, the loudspeakers should be transported and stored in a safe, careful, dry and largely dust-free manner.

The following accessory parts for the swivel bracket are available from TWAUDI^o:

- Hexagon screw M10 x 20
- Washer (metal)
- Rubber break washer
- Adaptor plate
- Countersunk screw M5 x 20 black
- HSF (pole mount flange)
- DHST (doughty halfcoupler slimline)

The original packaging is unsuitable as permanent storage and transport packaging.

6. CE Conformity Declaration

Copy and translation of the original CE Conformity Declaration:



We hereby declare that the below-referenced components by virtue of their design and construction, and in the configuration placed on the market by us, satisfy the safety and health requirements of the applicable EC directives. This declaration becomes invalid in case of modifications that have not been approved by us.

This declaration applies to the following components

- QBM10

as well as all model variants based on these, provided that they correspond to the original factory models and have not been technically modified in any way.

Applicable directives:

- 2001/95/EG

Applicable national standards and technical specifications:

- DIN EN 18800
- DIN EN ISO 12100
- DGUV Vorschrift 17 und 18

Berlin, Germany, January 1st, 2021



Bernhard Wüstner

7. Disposal

If you have any question regarding the disposal of used devices, please contact us under the following telephone number:

+49 (0) 71 41 - 48 89 89 0

In countries outside of the European Union, comply with local regulations.

TWAMBO GmbH
Karl-Hofer-Str. 42
14163 Berlin
Germany

Phone: + 49 (0) 71 41-48 89 89 0
Fax: + 49 (0) 71 41-48 89 89 99
E-Mail: info@twaudio.de
WWW: www.twaudio.de